

SOLENOID VALVES



OIL BURNER PUMPS

Series PT



CHARACTERISTICS

Applications:

- Light Oil.
- Normally closed.
- Oil cut-off and seal device.
- Two versions:
 - (1) with cable type M81
 - (2) with plug type F84

DIMENSIONS OF THE VALVE

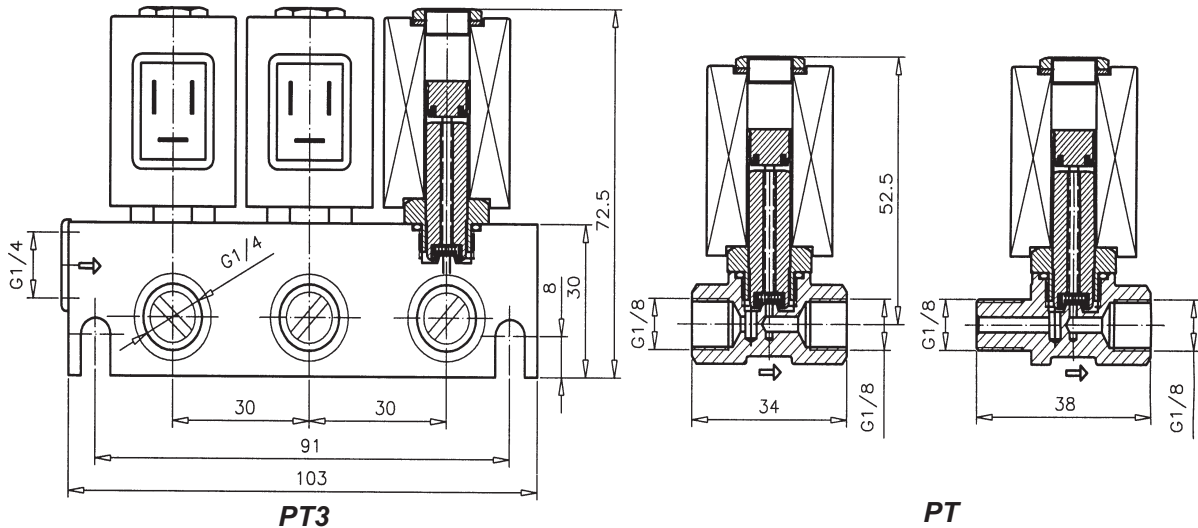

COILS

M81

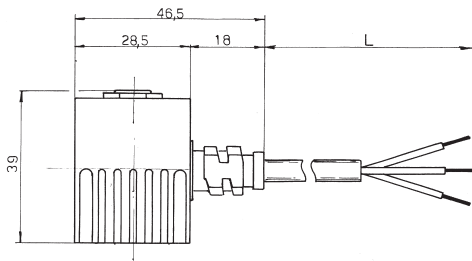

Coil M81 is with provided built-in cable (H03VV-F3/0,75).

F84

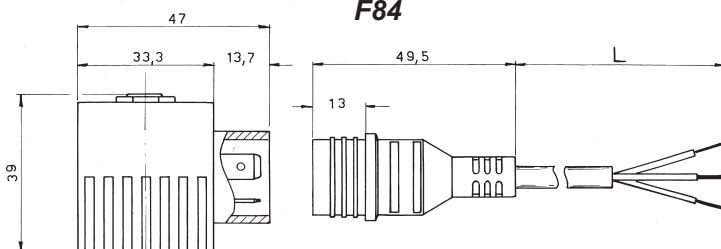

Coil F84 il provided with separated plug and cable (H03VV-F3/0,75)

TECHNICAL DATA

GENERAL DATA

Operating pressure	20 bar max
Power absorption	9 W
Oil temperature	60°C max
Ambient temperature	0-60°C
Protection class	IP 65
Flow factor (Kv)	0,08 m ³ /h (type PT) 1,00 m ³ /h (type PT3)
Orefice	Ø 1,7mm (type PT) Ø 1,9-2mm (type PT3)
Viscosity range	10 cSt max

MATERIALS

Body	Brass
Seal	FPM (Viton)
Plunger	Magnetic Steel
Coil covering	Nylon
Spring	Stainless Steel
O-ring	NBR
Cable	PVC

VOLTAGES

Supply Voltages	220-240V, 50Hz (TUV); 220-240V, 50/60Hz; 110V, 60Hz; 24V; 50Hz; 24V; DC
-----------------	---

CONNECTIONS

(1) 1/8" FF	female - female
(2) 1/8" M 1/8" F	male - female
(3) 1/8" M 1/4" M	male - male

1

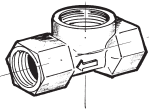

2

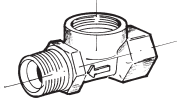

3

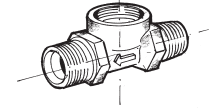

APPROVALS

Type PT and PT3 F84 220-240 V, 50Hz, approved by TÜV
Norms EN 264 and EN ISO 23553-1
Registration n°.



IDENTIFICATION OF THE VALVE

