

HEAVY OIL BURNER PUMP



Series N-NR



CHARACTERISTICS

Applications:

- Heavy oil.
- One pipe and two pipe systems.
- Self-priming.
- Manometer and vacuummeter connection.
- Drilling for heating cartridge.
- Capacity from 80 l/h to 420 l/h.

FUNCTION

The suction vacuum generated by the gears sucks up the fuel through the suction line; it crosses the filter and it is sent, under pressure, to the hydraulic valve which has cut-off function.

The hydraulic valve opens when oil pressure gets over spring strength settled by pressure adjustment screw and the oil reaches nozzle line.

In two pipe systems the exceeding oil flows into the tank through the return line; in one pipe system, after the removing the by-pass screw, it goes back to the gears.

When the burner stops, the oil pressure immediately comes down and the spring of the pressure adjustment screw, moves the piston which stops the fluid flow to the line and, at the same time, allows to the fluid to go through the return line.

Series NR pump is manufactured with a cavity for the insertion of an heater cartridge to maintain fluid the oil without direct contact and viton components.

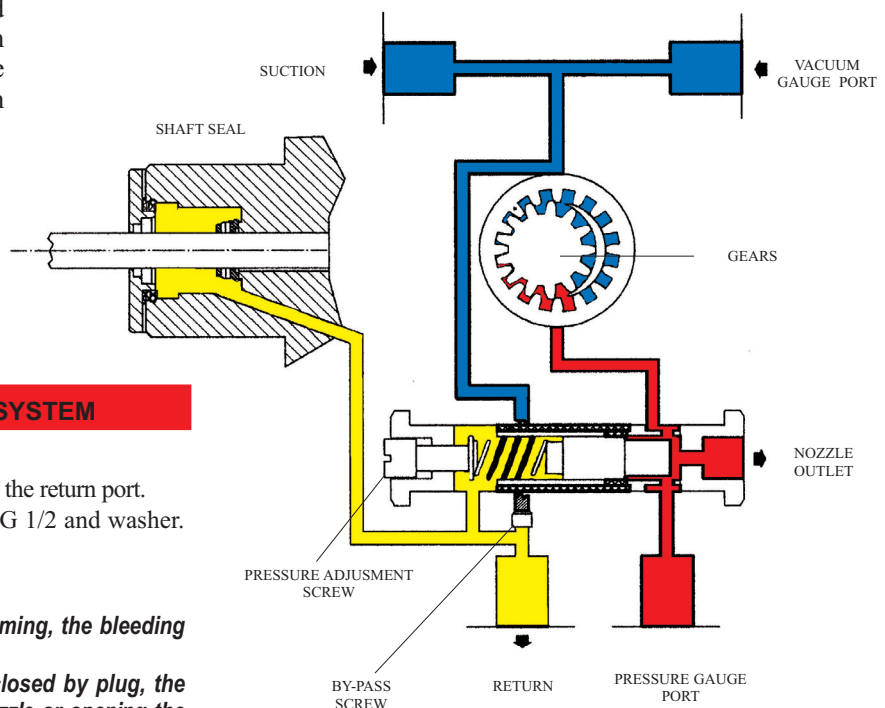

CONVERSION 2 PIPES - 1 PIPE SYSTEM

For the conversion proceed as follow:

- Remove the by-pass screw, located inside the return port.
- Lock the return port with a steel plug G 1/2 and washer.

ATTENTION:

In two-pipe system oil pump is self-priming, the bleeding is obtained through the return line.

In one-pipe system the return line is closed by plug, the bleeding must be obtained through the nozzle or opening the pressure gauge port, to accelerate the way out of the air.

TECHNICAL DATA

HYDRAULIC DATA

Factory settings	20 bar
Pressure range	7 - 28 bar
Viscosity range (series N)	2,8 - 200 cSt
Viscosity range (series NR)	2,8 - 450 cSt
Oil temperature (series N)	70°C max
Oil temperature (series NR)	120°C max
Inlet pressure	4 bar max
Return pressure	4 bar max
Suction height	0,45 bar max
Speed	2800 - 3480 rpm
Starting torque	0,35 Nm
Capacity	see graphs
Power consumption	see graphs

GENERAL DATA

Mounting	Flange \varnothing 54 mm according to EN 225
Connections	Nozzle outlet G 1/4 Pressure gauge port G 1/8 Vacuum gauge port G 1/2 Suction G 1/2 Return G 1/2
Strainer	Open area 142 cm ² Mesh 400 μ m
Weight	4,0 kg
Heating cartridge	\varnothing 10 mm according to EN 50262
Heating rating	50W 230V 50Hz

PRESSURE - CAPACITY DIAGRAM

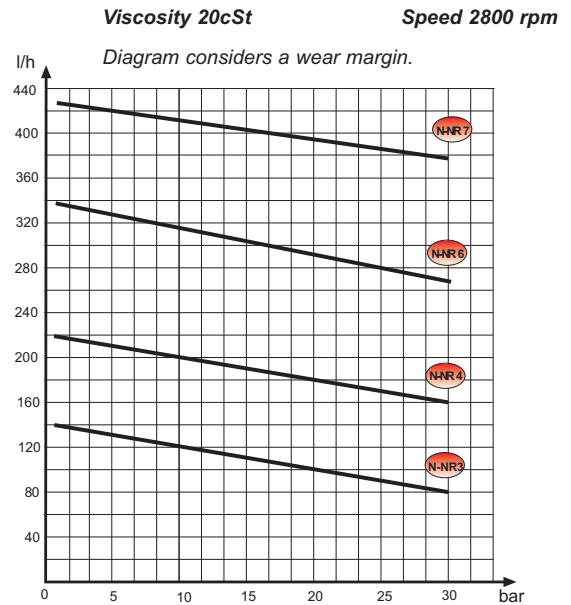

POWER CONSUMPTION - PRESSURE DIAGRAM

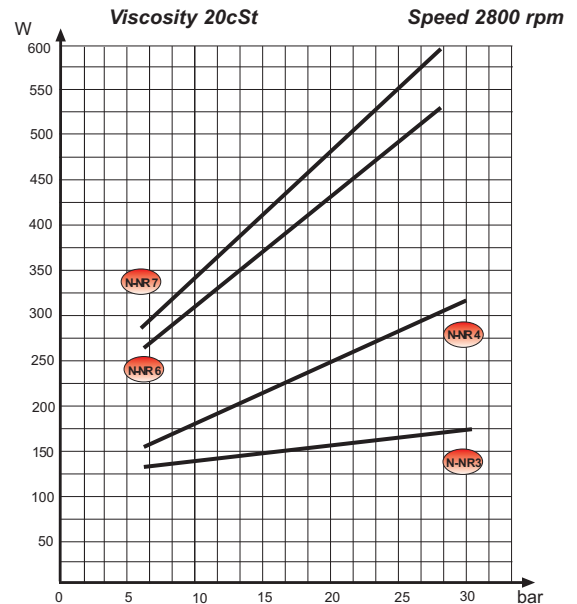

DIMENSIONS OF THE PUMP

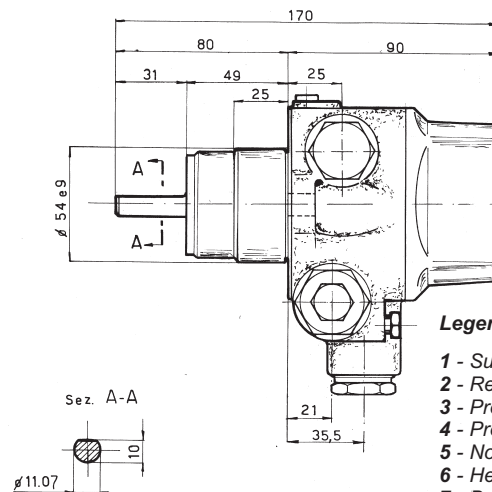
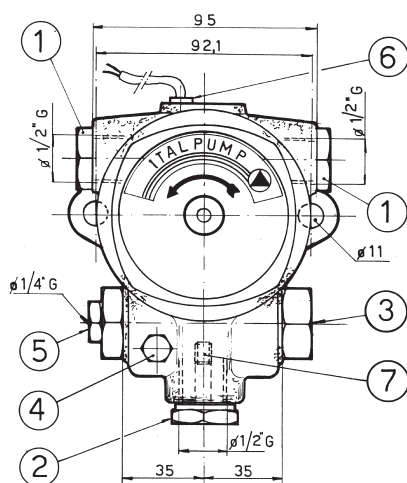

Pump type A.

Legend:

- 1 - Suction/Vacuum gauge port
- 2 - Return
- 3 - Pressure adjustment screw
- 4 - Pressure gauge port
- 5 - Nozzle outlet
- 6 - Heater (type NR)
- 7 - By-pass screw (two pipe system)

COMPONENTS OF THE PUMP

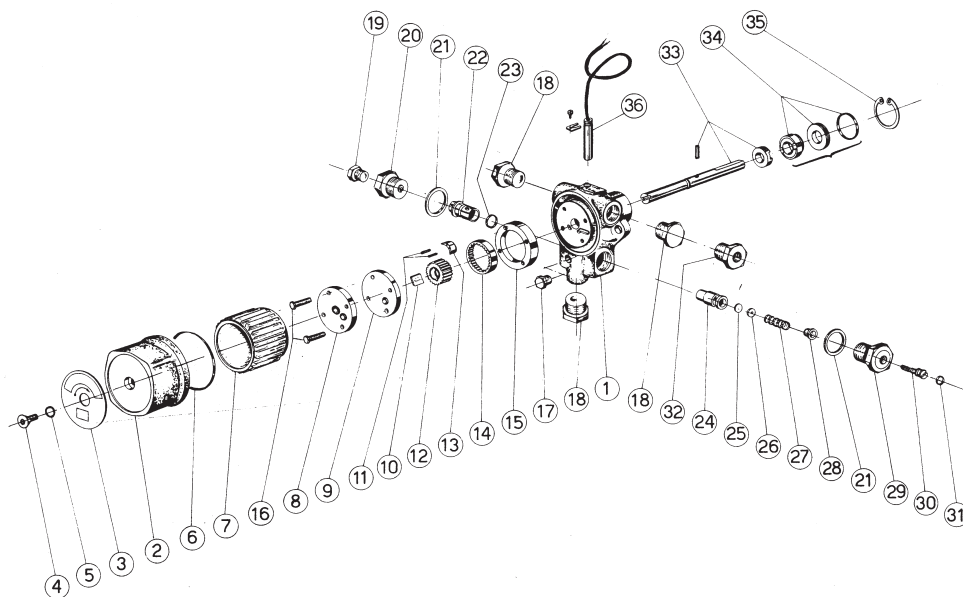

INSTALLATION OF THE PUMP

- The pump can be installed in all indicated positions.
- Make sure that the characteristics of the pump are compatible with those of the motor or of the boiler.
- Control the rotation of pump-motor.

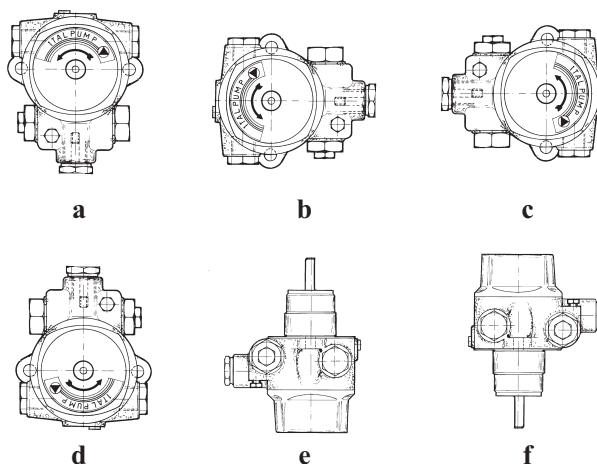

REGULATION OF THE PUMP PRESSURE

- Apply the manometer on the pressure gauge port.
- Rotate with the slotted screwdriver changing the pressure which has to be:
 - Pressure max: 28 bar
 - Pressure min: 7 bar

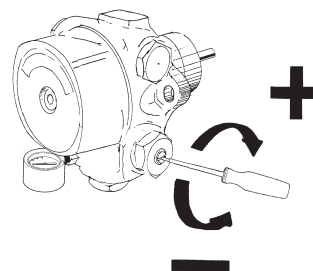

CLEANING OF THE FILTER

- Remove the cover as indicated in the figure.
- Extract the filter and clean it with the clean oil fuel.

ATTENTION: This operations have to be made periodically by the technical personnel.

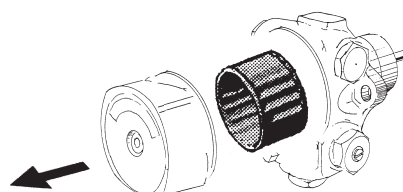

The repairs which require the substitution of pieces, must be realized by the manufacturer.

IDENTIFICATION OF THE PUMP

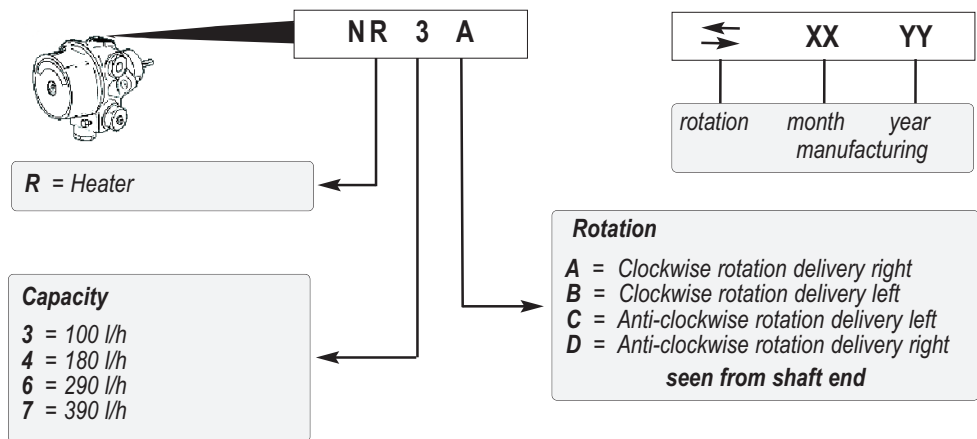

VERSIONS OF THE PUMP

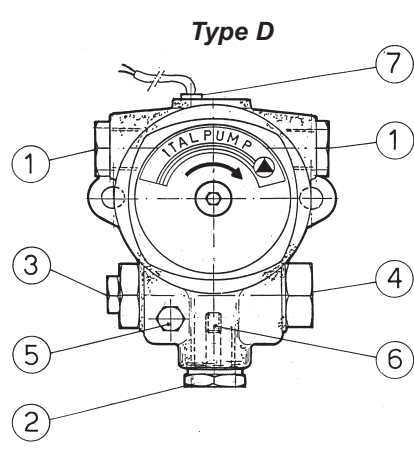
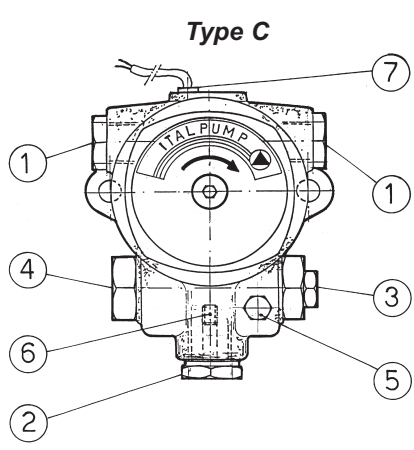
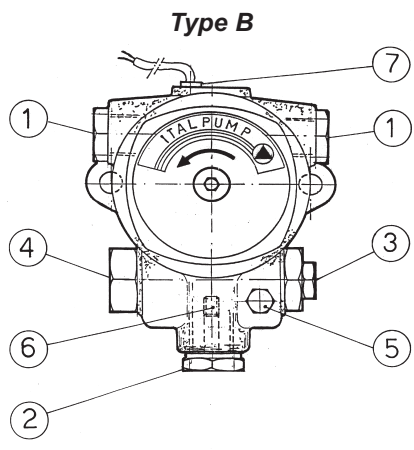
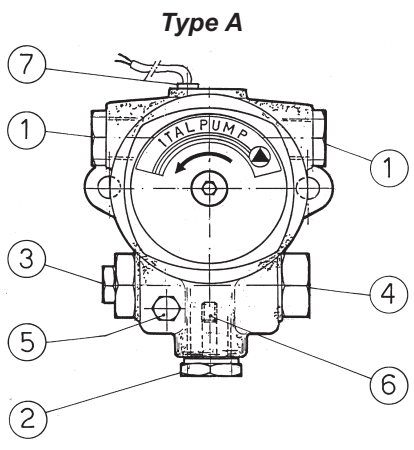

Legend:

- 1 - Suction/Vacuum gauge port
- 2 - Return
- 3 - Nozzle outlet
- 4 - Pressure adjustment screw
- 5 - Pressure gauge port
- 6 - By-pass screw (two pipe system)
- 7 - Heater (type NR)