

SCREW PUMP



OIL BURNER PUMPS

Series ITVH

CHARACTERISTICS

Applications:

- High pressure 10 - 35 bar.
- Fuel and lubricant without abrasive contents.
- High volumetric efficiency.
- Hydraulically balanced.
- Very low noise (52-53 dBA at 1425 rpm).
- Pressure regulator valve included.
- Capacity from 2000 l/h to 5400 l/h (light oil 1425 rpm)

TECHNICAL DATA

HYDRAULIC DATA

Suction inlet	see tables
Delivery outlet	see tables
Suction vacuum	0,45 bar/max
Viscosity range	6 - 800 cSt (1,5°E - 100°E)
Fluid temperature range	-20°C/+140°C
Speed	2900 rpm Light Oil 1450 rpm Heavy Oil
Noise level	52 - 53 dBA at 2900 rpm
Motors	220-240V 380-400V Three-phase 50Hz (standard) Three-phase 60Hz (on request)
Materials	Pump's body - cast iron Rotors - steel Shaft seal - viton

DIMENSIONS OF THE PUMP

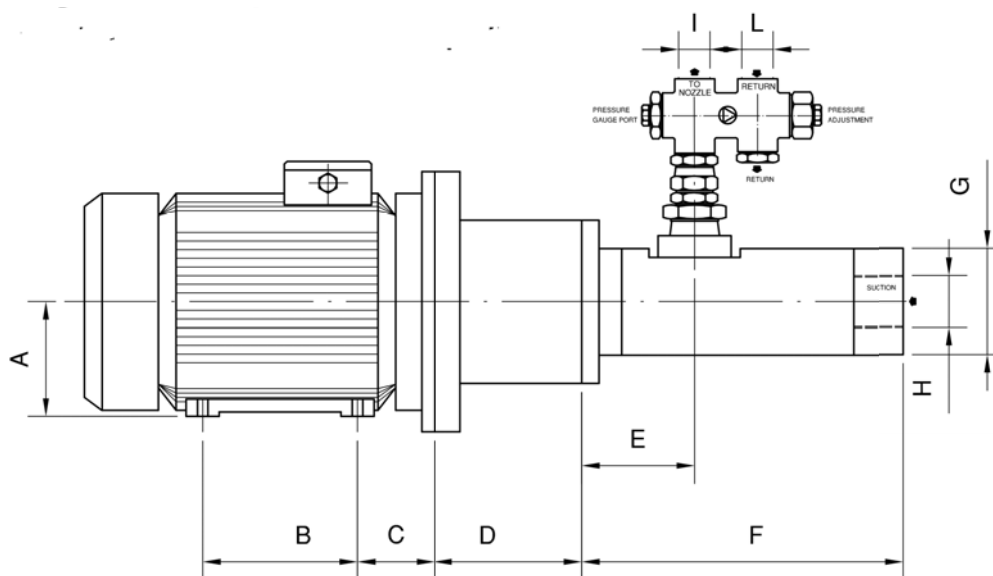

TYPE	A	B	C	D	E	F	G	H	I	L
ITVH 25 25L	90	125	56	113	112	302	65	G3/4"	G3/4"	G 314"
ITVH 25 30L	90/100	125/140	56/63	113	112	302	65	G3/4"	G3/4"	G 314"
ITVH 32 35L	90/100/112	125/140	56/63/170	113	109	290	94	G 1"1/4	G3/4"	G 314"
ITVH 32 45L	100/112	140	63/70	136	109	290	94	G 1"1/4	G3/4"	G 314"
ITVH 32 55L	100/112	140	63/70	136	109	290	94	G 1"1/4	G3/4"	G 314"
ITVH 32 75L	100/112	140	63/170	136	109	290	94	G 1"1/4	G3/4"	G 314"
ITVH 40 SOL	100/112	140	63/170/89	136	125	343	108	G 1"1/2	G3/4"	G 314"
ITVH 40 100L	100/112/132	140	63/170/89	136	125	343	108	G 1"1/2	G3/4"	G 314"
ITVH 40 125L	132	178	89	170	125	343	108	G 1"1/2	G3/4"	G 3/4"
ITVH 40 150L	132/160	140/178	89/108	170	125	343	108	G 1"1/2	G3/4"	G 314"
ITVH 45 180L	132/160	176/1210	89/108	170/195	130	371	123	G2"	G3/4"	G 314"
ITVH 45 210L	132/160	176/1210	89/108	170/195	130	371	123	G2"	G3/4"	G 314"
ITVH 55 250L	132/160	176/1210	89/108	170/195	143	428	143	G 2"1/2	G3/4"	G 314"
ITVH 55 300L	160	210	108	205	143	428	143	G 2"1/2	G3/4"	G 3/4"
ITVH 55 330L	160	210	108	205	143	428	143	G 2"1/2	G3/4"	G 314"
ITVH 55 380L	160	210	108	205	143	428	143	G 2"1/2	G3/4"	G 3/4"

PRESSURE - CAPACITY DIAGRAM

Speed 1450 rpm

Viscosity 68 cSt (9°E)

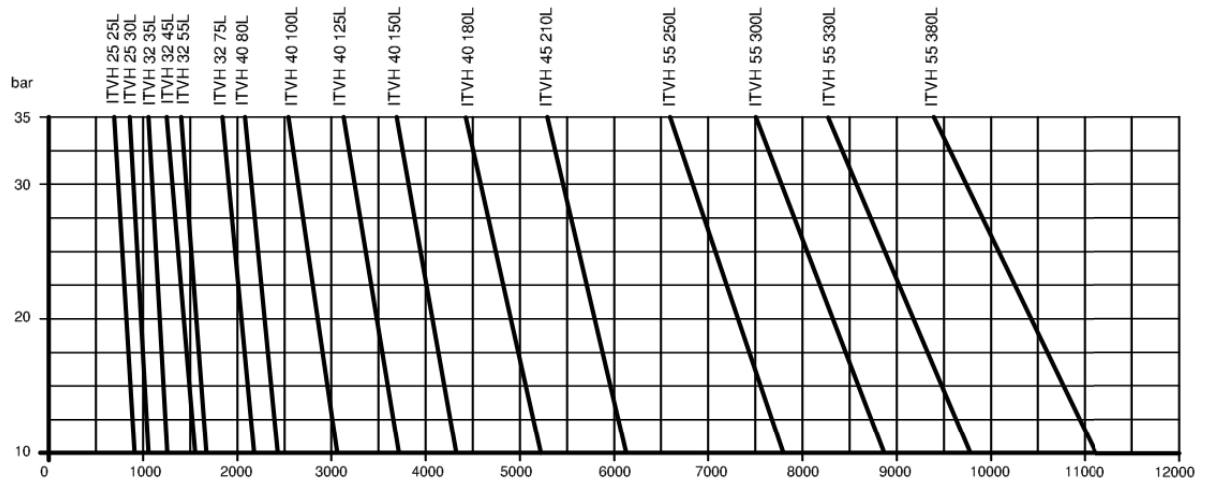

Speed 1450 rpm

Viscosity 6 cSt (1,5°E)

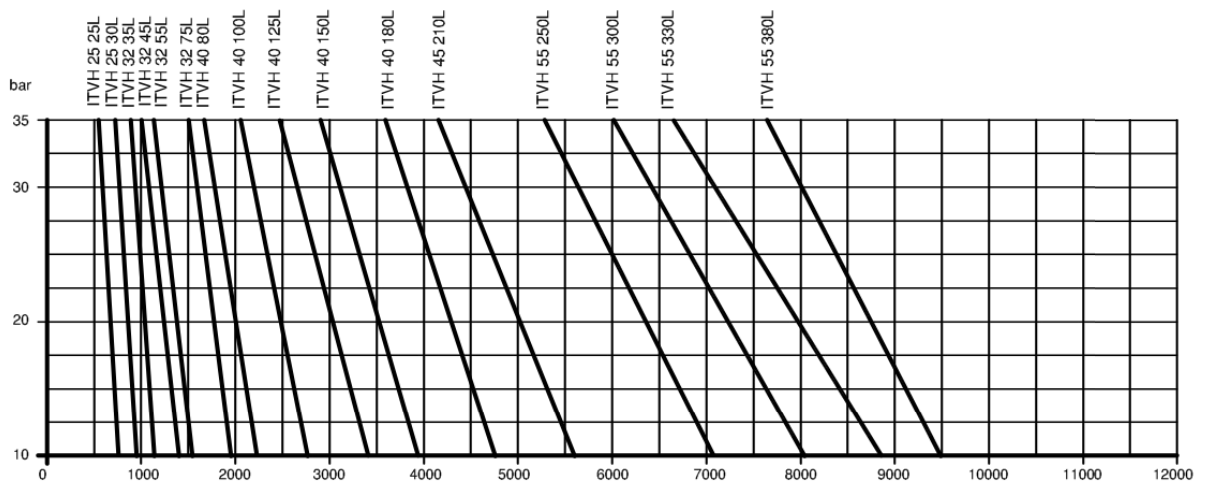

POWER CONSUMPTION - PRESSURE DIAGRAM

Speed 1450 rpm

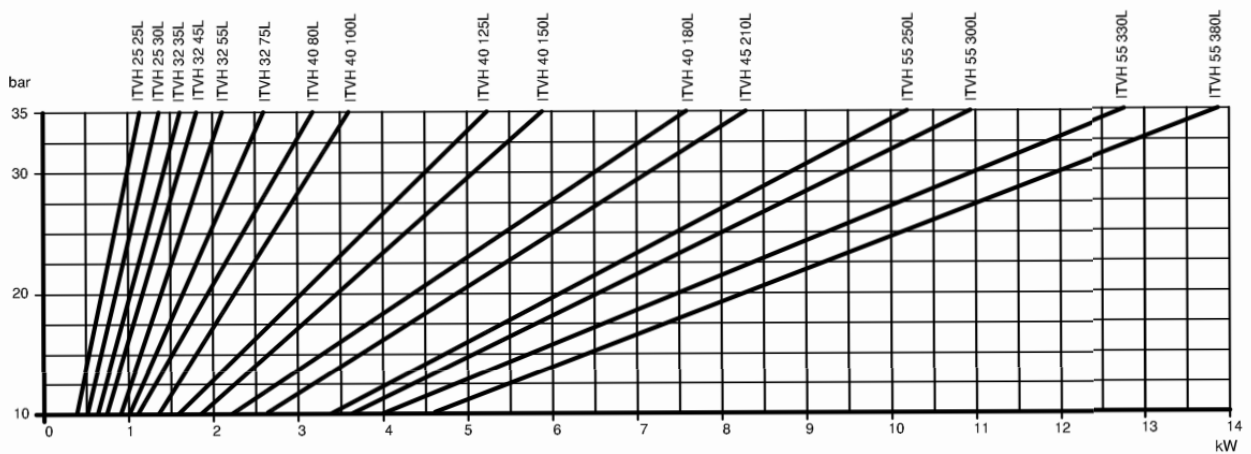

PRESSURE - CAPACITY DIAGRAM

Speed 2900 rpm

Viscosity 68 cSt (9°E)

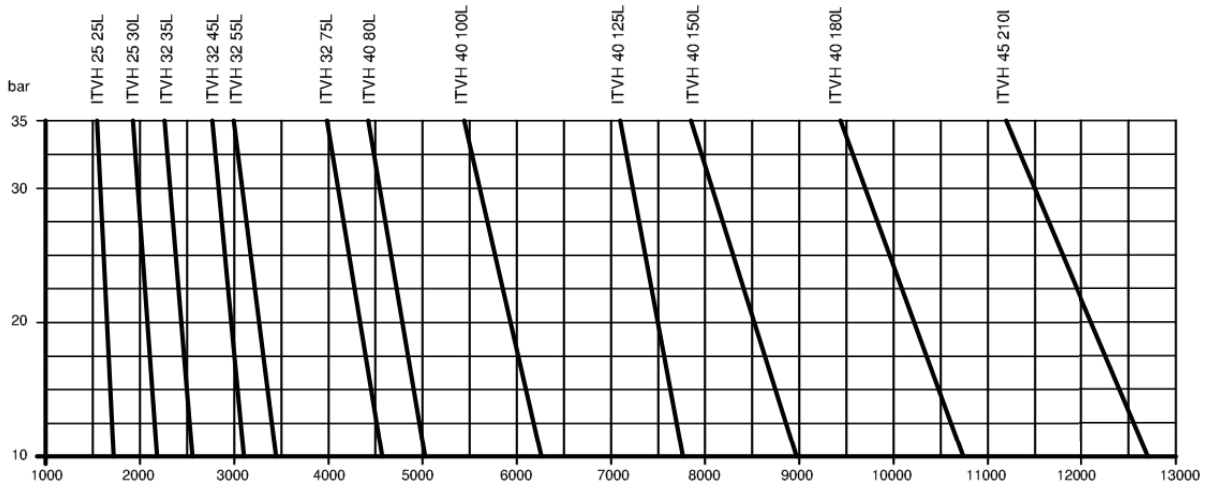

Speed 2900 rpm

Viscosity 6 cSt (1,5°E)

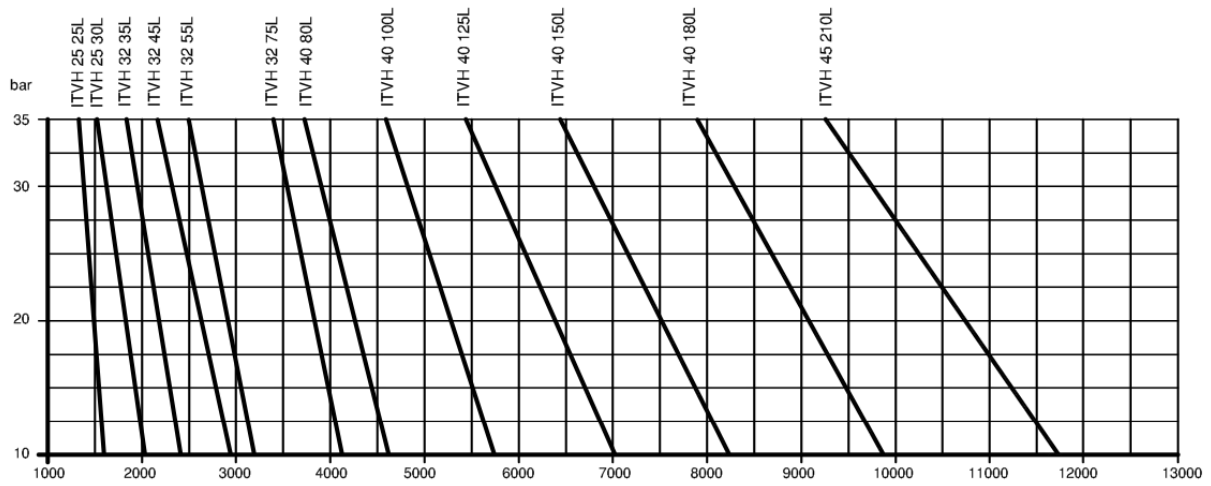

POWER CONSUMPTION - PRESSURE DIAGRAM

Speed 2900 rpm

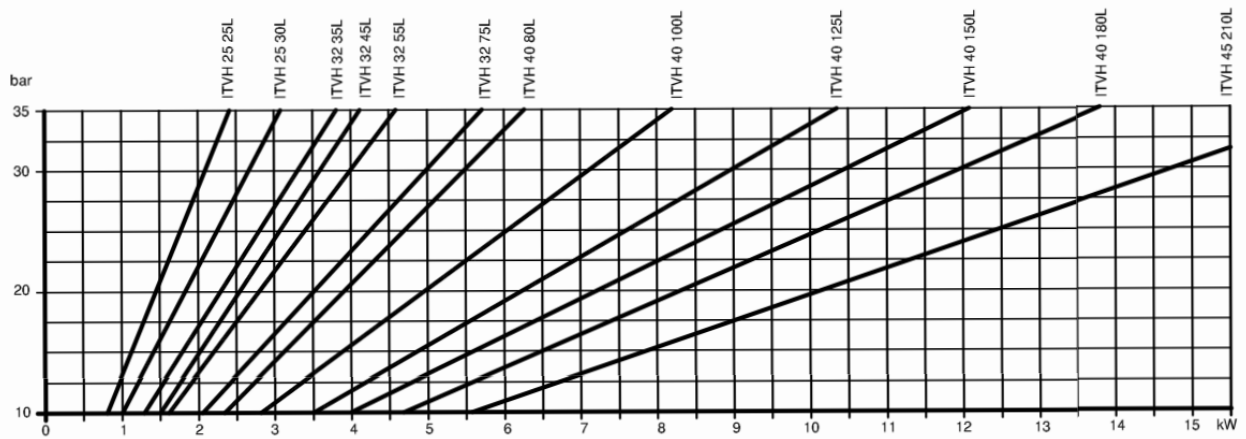

MOTOR PUMP CAPACITY

PUMP CAPACITY l/h 2900 rpm 50 Hz (2 POLES MOTOR)								
TYPE	l/h 68 cSt - kW ass.			l/h 6 cSt - kW ass.			MOTOR (for 30 bar)	
	10 bar	20 bar	30 bar	10 bar	20 bar	30 bar	68 cSt SIZE-Kw	6 cSt SIZE kW
ITVH 25 25L	1740 - 0.8	1660 - 1.3	1580 - 2.1	1608 - 0.75	1465 - 1.2	1345 - 2	90L - 2.2	90L - 2.2
ITVH 25 30L	2180 - 1	2070 - 1.7	1970 - 2.7	2009 - 0.95	1836 - 2.6	1670 - 2.6	100L - 3	100L - 3
ITVH 32 35L	2560 - 1.3	2450 - 2.2	2322 - 3.3	2376 - 1.2	2167 - 2.1	1977 - 3	112 - 4	100L - 3
ITVH 32 45L	3130 - 1.5	3010 - 2.5	2850 - 3.6	2916 - 1.4	2340 - 2.4	2110 - 3.5	112 - 4	112 - 4
ITVH 32 55L	3430 - 1.6	3264 - 2.7	3100 - 4	3160 - 1.5	2881 - 2.6	2640 - 3.8	112M-5.5	112 - 4
ITVH 32 75L	4560 - 2.1	4350 - 3.5	4130 - 5	4158 - 2	3825 - 3.4	3540 - 5.2	112M-5.5	112M-5.5
ITVH 40 80L	5020 - 2.3	4790 - 3.8	4530 - 5.5	4644 - 2.2	4207 - 3.7	3840 - 5.4	112M-5.5	112M-5.5
ITVH 40 100L	6270 - 2.8	5970 - 4.7	5670 - 7.2	5788 - 2.7	5253 - 4.6	4800 - 6.5	132S-7.5	132S-7.5
ITVH 40 125L	7800 - 3.5	7500 - 6	7250 - 9	7020 - 3	6222 - 5	5760 - 7.5	132M-9.2	132S-7.5
ITVH 40 150L	8950 - 4	8540 - 6.7	8100 - 10.5	8260 - 3.8	7497 - 6.7	6864 - 9.2	160M-11	132M-9.2
ITVH 45 180L	10700 - 4.7	10200 - 8	9720 - 12	9882 - 4.5	9027 - 7.9	8256 - 11	160M-15	160M-11
ITVH 45 210L	12700 - 5.6	12100 - 9.6	11500 - 14.8	11718 - 5.4	10710 - 9.3	9744 - 14	160M-15	160M-15

PUMP CAPACITY l/h 1450 rpm 50 Hz (4 POLES MOTOR)								
TYPE	l/h 68 cSt - kW ass.			l/h 6 cSt - kW ass.			MOTOR (for 30 bar)	
	10 bar	20 bar	30 bar	10 bar	20 bar	30 bar	68 cSt SIZE-Kw	6 cSt SIZE kW
ITVH 25 25L	840 - 0.4	790 - 0.6	745 - 1	772 - 0.4	683 - 0.6	609 - 1	90S - 1.1	90S - 1.1
ITVH 25 30L	1050 - 0.5	990 - 0.8	923 - 1.2	966 - 0.5	862 - 0.8	768 - 1.2	90L - 1.5	90L - 1.5
ITVH 32 35L	1250 - 0.6	1170 - 1	1100 - 1.4	1134 - 0.6	1009 - 1	962 - 1.4	90L - 1.5	90L - 1.5
ITVH 32 45L	1530 - 0.7	1440 - 1.1	1350 - 1.6	1393 - 0.7	1239 - 1.1	1108 - 1.6	100L - 1.8	100L - 1.8
ITVH 32 55L	1660 - 0.8	1560 - 1.2	1450 - 1.8	1512 - 0.8	1351 - 1.2	1204 - 1.8	100L - 2.2	100L - 2.2
ITVH 32 75L	2220 - 1	2090 - 1.7	1940 - 2.3	1971 - 0.9	1790 - 1.6	1608 - 2.2	100L - 3	100L - 2.2
ITVH 40 80L	2450 - 1.1	2290 - 1.9	2140 - 2.8	2219 - 1.1	1983 - 1.8	1776 - 2.6	100L - 3	100L - 3
ITVH 40 100L	3020 - 1.3	2840 - 2.3	2670 - 3.2	2754 - 1.2	2448 - 2.2	2208 - 3	112M - 4	100L - 3
ITVH 40 125L	3700 - 1.6	3450 - 2.8	3240 - 4.5	3384 - 1.5	3009 - 2.7	2640 - 4.2	132S-5.5	132S-5.5
ITVH 40 150L	4330 - 1.8	4070 - 3.2	3830 - 5.1	3942 - 1.7	3493 - 3.1	3144 - 4.6	132S-5.5	132S-5.5
ITVH 45 180L	5180 - 2.2	4900 - 3.9	4590 - 6.5	4752 - 2	4233 - 3.8	3792 - 5.2	132M-7.5	132S-5.5
ITVH 45 210L	6150 - 2.6	5800 - 4.6	5450 - 7.2	5616 - 2.5	4998 - 4.5	4464 - 6.5	132M-7.5	132M-7.5
ITVH 55 250L	7800 - 3.4	7300 - 6	6850 - 8.8	7074 - 3.3	6324 - 6	5664 - 8.5	132M-9.2	132M-9.2
ITVH 55 300L	8830 - 3.6	8300 - 6.4	7770 - 9.5	8046 - 3.5	7140 - 6.2	6432 - 8.8	160M-11	132M-9.2
ITVH 55 330L	9740 - 4	9150 - 7.2	8580 - 11	8858 - 3.8	7905 - 6.5	7056 - 9.5	160M-11	160M-11
ITVH 55 380L	11100 - 4.6	10380 - 8.4	9720 - 12	9450 - 4.5	8925 - 18	8016 - 11.5	160L-15	160L-15

Note:

With 60 Hz motor pump capacity +20%.
 With heavy oil use 1450/1750 rpm.

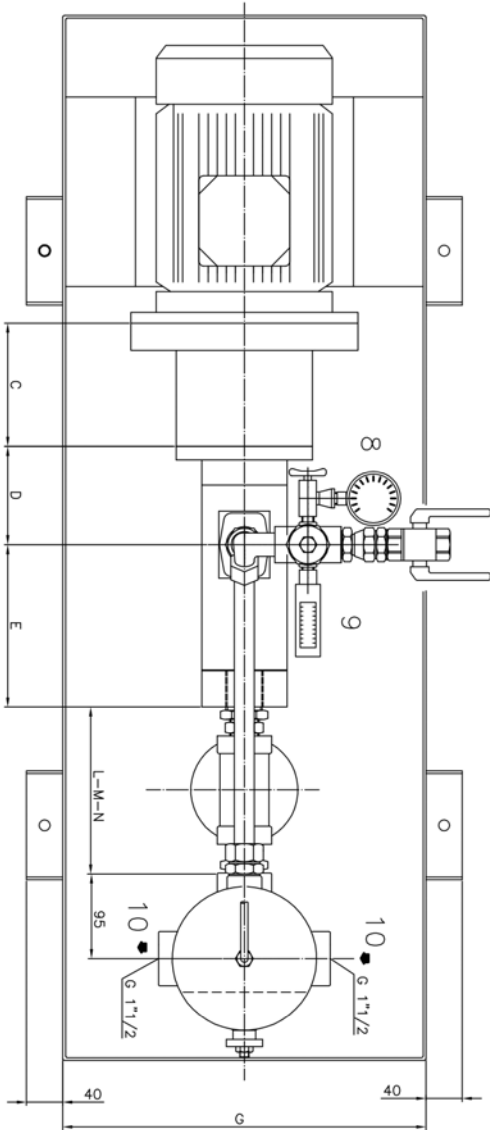
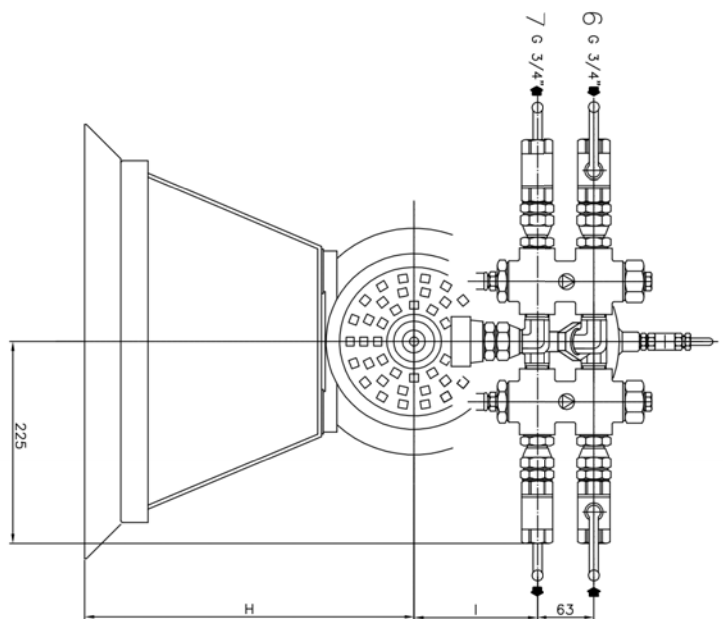
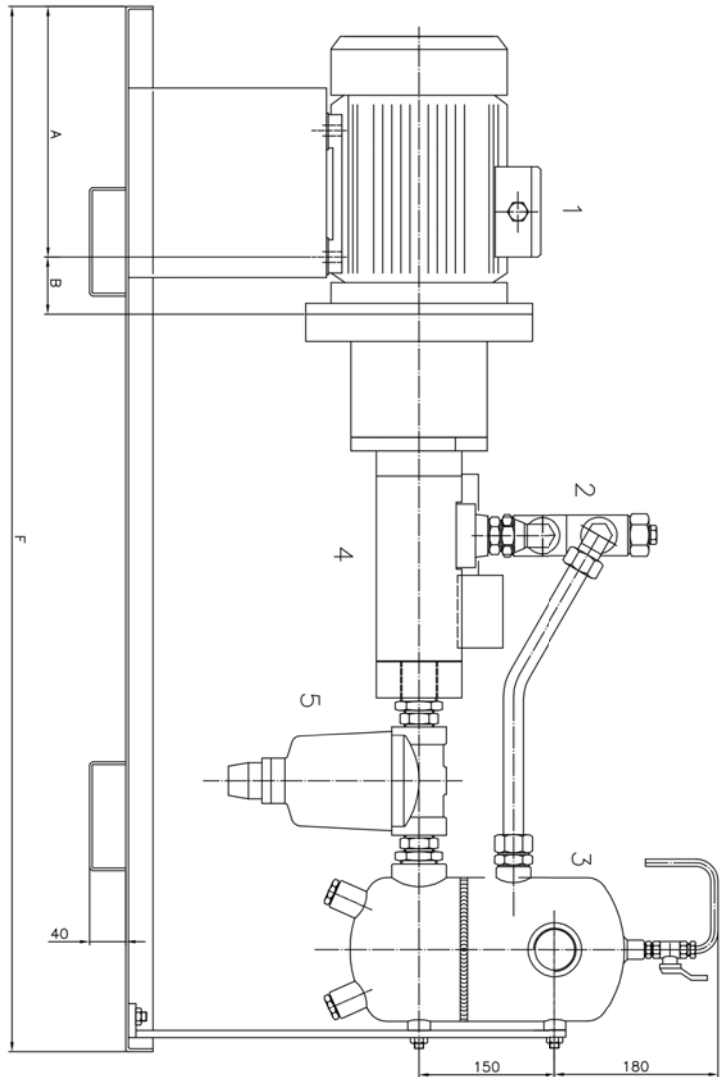

Legend:

- 1 - Motor
- 2 - Pressure regulator
- 3 - Air separator
- 4 - Screw pump
- 5 - Filter
- 6 - Burner return
- 7 - Burner delivery
- 8 - Pressure gauge
- 9 - Min pressure switch
- 10 - Inlet/Outlet ring

1x1

