

HEAVY OIL BURNER PUMP



Series ITP



CHARACTERISTICS

Applications:

- Heavy oil and light oil.
- One pipe and two pipe system.
- Drilling for heating cartridge.
- Capacity from 350 l/h to 1380 l/h.

FUNCTION

Oil suction from the tank is generated by the rotation of the gear set. Sucked oil first reaches the gear set, by which it is compressed and sent to the hydraulic valve.

The hydraulic valve opens when oil pressure gets over spring strength settled by pressure adjustment screw and the oil reaches nozzle line.

In two pipe systems the exceeding oil flows into the tank through the return line; in one pipe system after removing the by-pass screw, it goes back to the gear.

On burner stop, the oil pressure immediately comes down and the spring strength, move the piston which stop the fluid flow to the line and at the same time allows the forwarding of the light oil to the return line.

The pump is manufactured with a drilling for the insertion of an heater cartridge to maintain fluid the oil without direct contact. It is very important to avoid damages, especially at the starting of the pump, that the viscosity of the oil is not too high. We suggest to keep on the cartridge during the pump operation.

BLEEDING:

In two-pipe system oil pump is self-priming, the bleeding is obtained through the return connection. In one pipe systems the return line is closed by the steel plug and washer, the bleeding must be obtained loosing the pressure gauge port.

CONVERSION 2 PIPES - 1 PIPE SYSTEM

For the conversion proceed as follow:

- Remove the by-pass screw located inside the return port.
- Lock the return port with a steel plug G 1/2 and washer.



SEEN FROM THE SHAFT END

R - Return G 1/2
PR - Pressure adjustment screw



ANTICLOCKWISE

- A - Suction G 1/2
- S - Nozzle outlet G 1/2
- M - Pressure gauge port G 1/4
- V - Vacuum gauge port G 1/4



CLOCKWISE

- A1 - Suction G 1/2
- S1 - Nozzle outlet G 1/2
- M1 - Pressure gauge port G 1/4
- V1 - Vacuum gauge port G 1/4

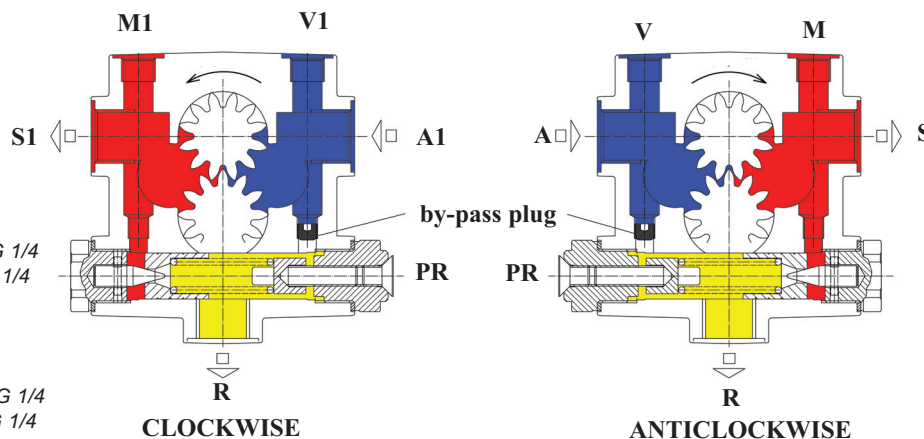

TECHNICAL DATA

HYDRAULIC DATA

Factory settings	20 bar
Pressure range	8 - 35 bar
Viscosity range	5 - 450 cSt
Oil temperature	150°C max
Inlet pressure	4 bar max
Return pressure	4 bar max
Suction height	0,45 bar max
Speed	3600 rpm
Capacity	see graphs
Power consumption	see graphs

GENERAL DATA

Mounting	Flange \varnothing 54 mm according to EN 225
Shaft	\varnothing 12 mm
Connections	Nozzle outlet G 1/2
	Pressure gauge port G 1/4
	Vacuum gauge port G 1/4
	Suction G 1/2
	Return G 1/2
Weight	ITP 2 5,5 kg
	ITP 3 5,7 kg
	ITP 4 5,9 kg
	ITP 5 6,1 kg
Heating cartridge	\varnothing 10 mm according to EN 50262
Heating rating	110W 230V 50Hz

PRESSURE - CAPACITY DIAGRAM

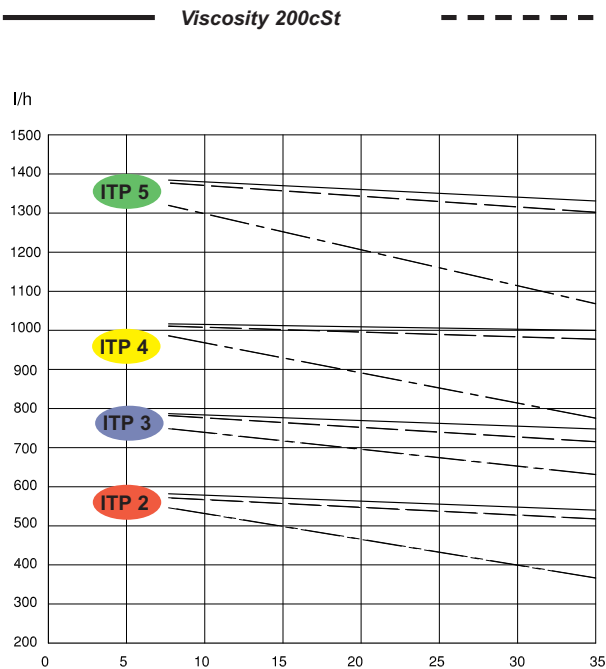

POWER CONSUMPTION - PRESSURE DIAGRAM

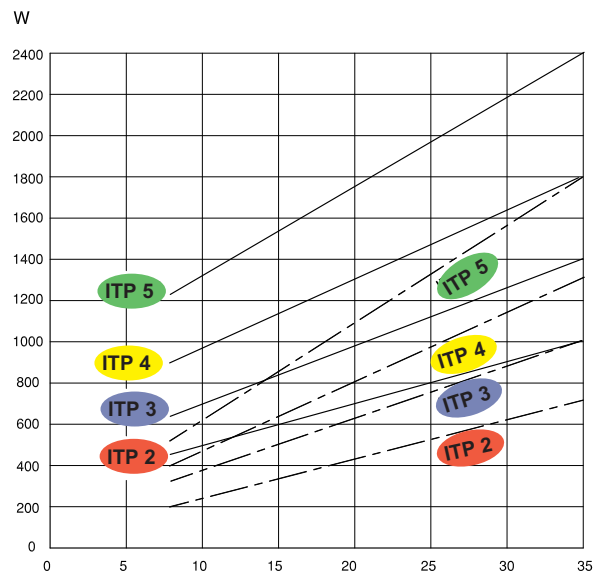

DIMENSIONS OF THE PUMP

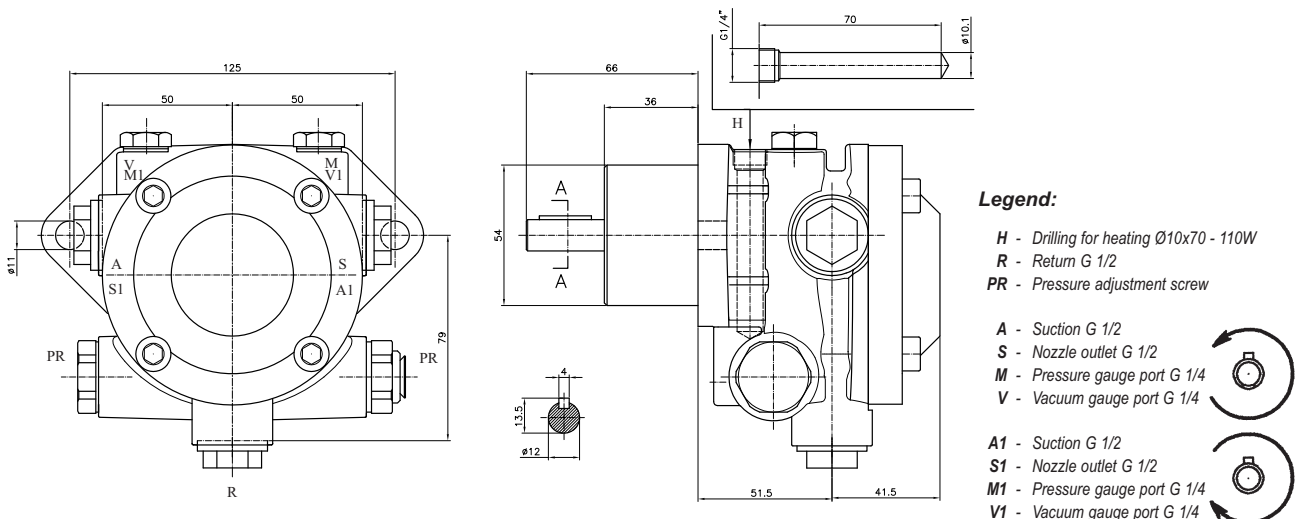

INSTALLATION OF THE PUMP

- The pump can be installed in all indicated positions.
- Make sure that the characteristics of the pump are compatible with those of the motor or of the boiler.
- Control the rotation of pump-motor.

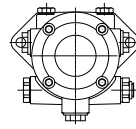

a

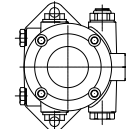

b

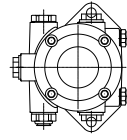

c

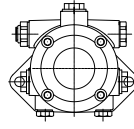

d

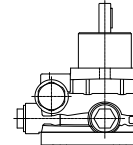

e

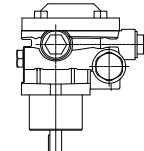

f

REGULATION OF THE PUMP PRESSURE

- Apply the manometer on the pressure gauge port (M).
- Rotate with the allen key of 5 mm changing the pressure which has to be:
 - Pressure max: 35 bar
 - Pressure min: 8 bar

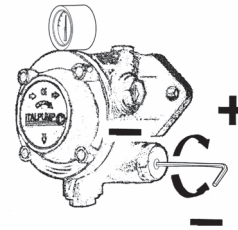

IDENTIFICATION OF THE PUMP

