

## LIGHT OIL BURNER PUMP

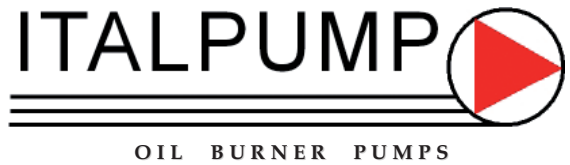

### Series GBE/KBE

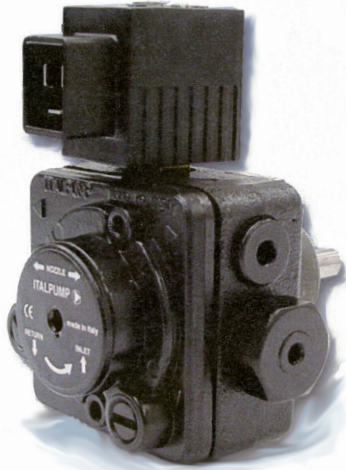

### CHARACTERISTICS

#### Applications:

- Light oil (GBE) or kerosene (KBE).
- One pipe or two pipe system.
- Single stage.
- Cartridge filter.
- Solenoid valve, normally closed, with cut-off function.
- Capacity from 25 l/h to 83 l/h.

### FUNCTION

The suction vacuum generated by the gears sucks up the fuel through the suction line "A"; it crosses the filter and it is sent under pressure to the pressure adjustment screw "RG".

During the prepurge cycle the "NC" solenoid valve prevents the exit of the fuel from the nozzle outlet "U".

When the voltage is applied to the "NC" solenoid valve, the fuel is sent to the nozzle at the pressure value set by pressure adjustment screw "RG", only the exceeding fuel is sent on the return line "R". In the one-pipe system the by-pass screw "B" is removed and the return line "R" is plugged; the whole fuel is sucked up by the gears without crossing another time through the filter.

During the operation it is possible to measure the suction vacuum by the vacuum gauge port "V" and the pressure by the pressure gauge port "P"; it is also available on the pump an auxiliary delivery port "P1".

When the burner stops the voltage to the "NC" solenoid valve is cut-off and immediately the oil flows to the return line "R".

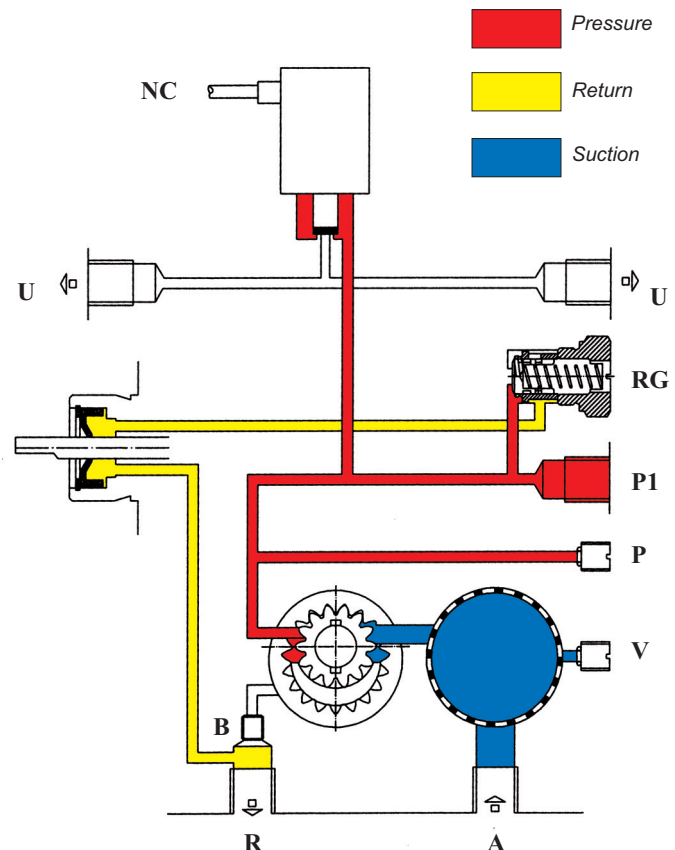

### CONVERSION 2 PIPES - 1 PIPE SYSTEM

For the conversion proceed as follow:

- Remove the by-pass screw, located inside the return port "R".
- Lock the return port with a steel plug G 1/4 and washer.

#### ATTENTION:

*In two-pipe system oil pump is self-priming, the bleeding is obtained through the return line.*

*In one-pipe system the return line is closed by plug, the bleeding must be obtained through the nozzle or opening the pressure gauge port "P", to accelerate the way out of the air.*

## GBE TECHNICAL DATA

### HYDRAULIC DATA

Factory settings	10 bar
Pressure range	5 - 20 bar
Viscosity range	2 - 12 cSt
Oil temperature	0 - 60°C
Inlet pressure	1,5 bar max
Return pressure	1,5 bar max
Suction height	0,45 bar max
Speed	2800 - 3480 rpm
Starting torque	0,10 Nm
Capacity	see graphs
Power consumption	see graphs

### GENERAL DATA

Mounting	Hub $\varnothing$ 32 mm according to EN 225	
Connections	Nozzle outlet	G 1/8
	Pressure gauge port	G 1/8
	Vacuum gauge port	G 1/8
	Suction	G 1/4
	Return	G 1/4
Nozzle outlet	Left and Right	
Filter	Open area	9 cm <sup>2</sup>
	Mesh	200 $\mu$ m
Weight	1,1 kg	

### SOLENOID VALVE DATA

Pressure max	20 bar
Voltages	220-240V, 110V, 24V;
	50/60Hz
Absorption	9 W
Ambient temperature	0-70°C

## PRESSURE - CAPACITY DIAGRAM

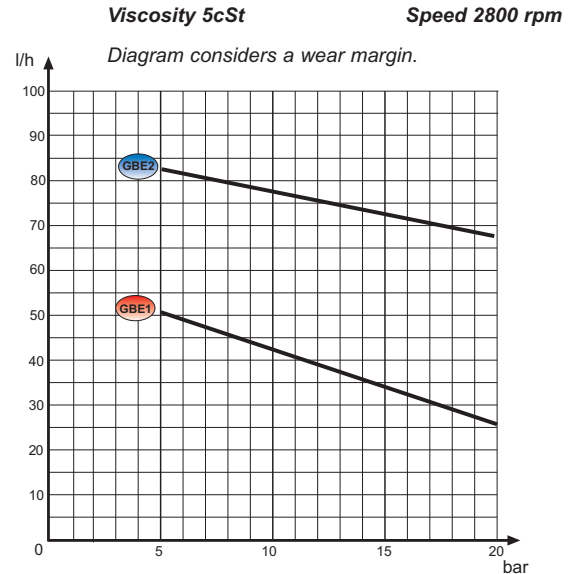

## POWER CONSUMPTION - PRESSURE DIAGRAM

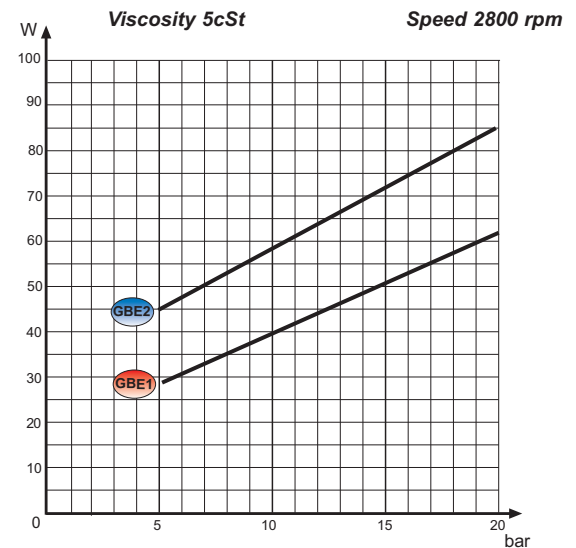

## DIMENSIONS OF THE PUMP

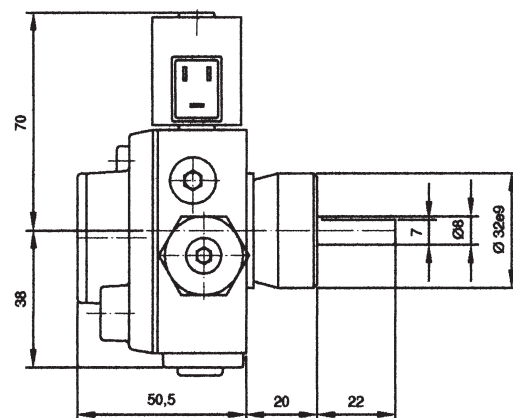
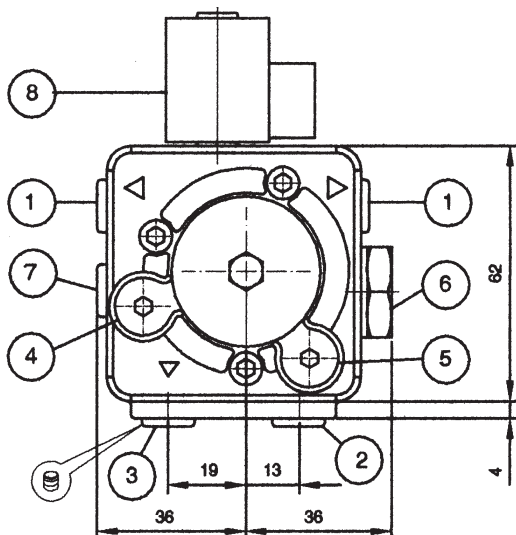

### Legend:

- |                               |                                   |
|-------------------------------|-----------------------------------|
| 1 - Nozzle outlet G 1/8       | 5 - Vacuum gauge port G 1/8       |
| 2 - Suction G 1/4             | 6 - Pressure adjustment screw     |
| 3 - Return G 1/4              | 7 - Auxiliary delivery port G 1/8 |
| 4 - Pressure gauge port G 1/8 | 8 - Solenoid valve N.C.           |



## COMPONENTS OF THE PUMP

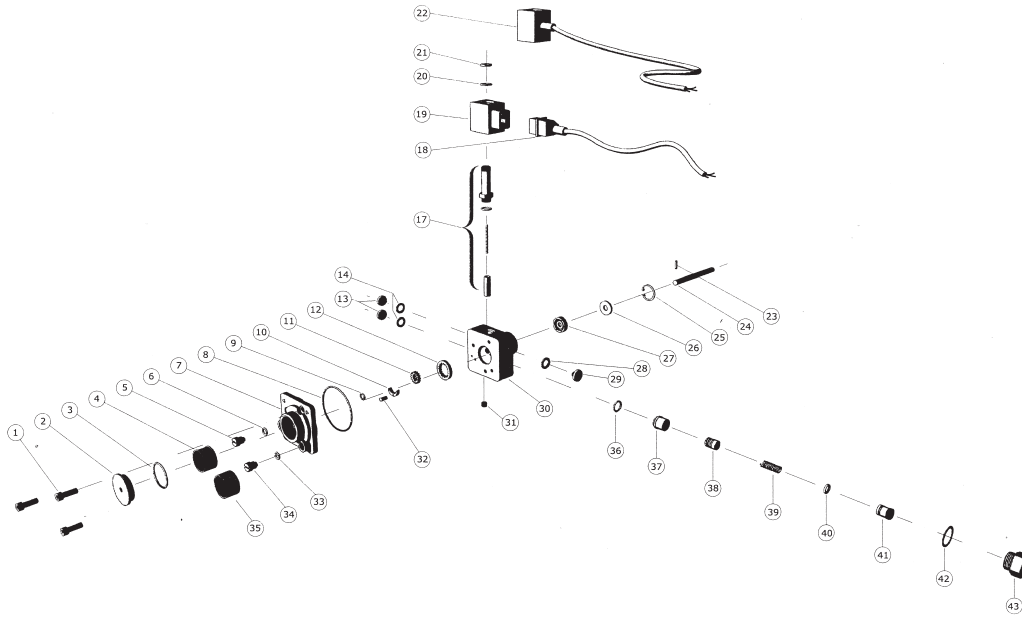

## INSTALLATION OF THE PUMP

• The pump can be installed in the indicated positions: it is suggested position **a**.

It has to be absolutely avoid the position **f**.

- Make sure that the characteristics of the pump are compatible with those of the motor or of the boiler.
- Control the rotation of pump-motor.



**The coupling pump-motor must be realized using 3 head screws without; otherwise you can have significant reductions of pump life.**

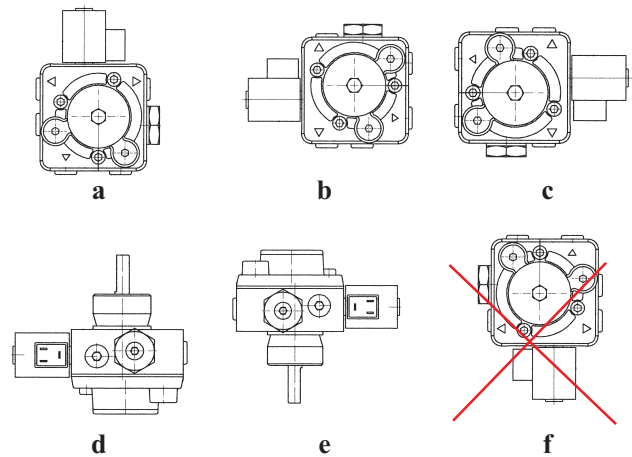

## REGULATION OF THE PUMP PRESSURE

- Apply the manometer on the pressure gauge port (P).
- Rotate with the allen key of 4 mm changing the pressure which has to be:

Pressure max: 20 bar (light oil) - 14 bar (kerosene)

Pressure min: 5 bar (light oil) - 4 bar (kerosene)

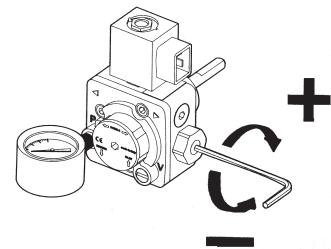

## CLEANING OF THE FILTER

- Remove the cover as indicated in the position 1.
- Extract the filter and clean it with the clen oil fuel. (position 2).

**ATTENTION: This operations have to be made periodically by the technical personnel.**

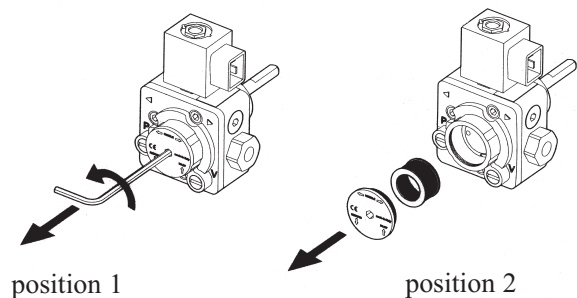

**The repairs which require the substitution of pieces, must be realized by the manufacturer.**