

LIGHT OIL BURNER PUMP



Series GB/KB



CHARACTERISTICS

Applications:

- Light oil(GB) or kerosene(KB).
- One pipe or two pipe system.
- Single stage.
- Cartridge filter.
- One in-line solenoid valve recommended.
- Capacity from 25 l/h to 83 l/h.

FUNCTION

The suction vacuum generated by the gears sucks up the fuel through the suction line “A”; it crosses the filter and it is sent under pressure to the pressure adjustment screw “RG”.

The fuel is sent to the nozzle at the pressure value set by “RG”, only the exceeding fuel is sent on the return line “R”.

In the one-pipe system the by-pass screw “B” is removed and the return “R” is plugged; the whole fuel is sucked up by the gears without crossing another time through the filter. During the operation it is possible to measure the suction vacuum by the vacuum gauge port “V” and the pressure by the pressure gauge port “P”; it is also available on the pump an auxiliary delivery port “P1”.

When the burner stops, instantly the pressure comes down and the spring of the pressure adjustment screw “RG” moves the piston which stops the oil flow to the line and allows to the fluid to go through the return line “R”.

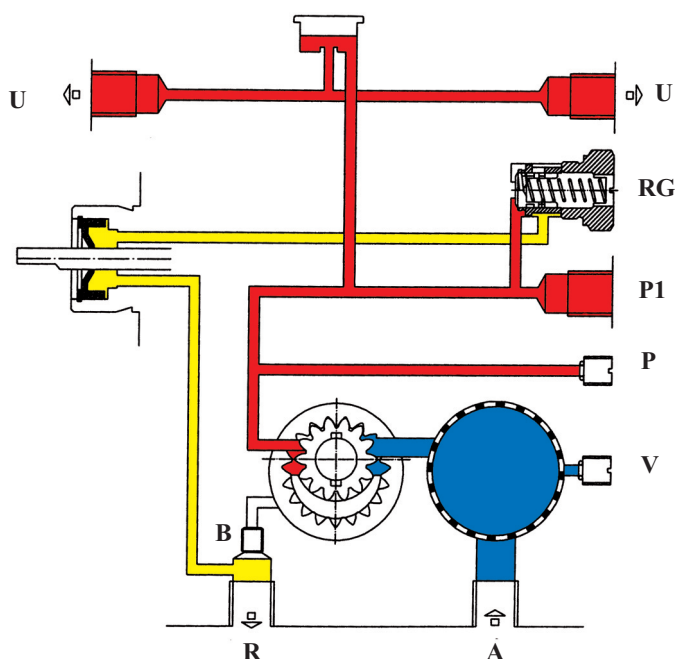

CONVERSION 2 PIPES - 1 PIPE SYSTEM

For the conversion proceed as follow:

- Remove the by-pass screw, located inside the return port “R”.
- Lock the return port with a steel plug G 1/4 and washer.

ATTENTION:

In two-pipe system oil pump is self-priming, the bleeding is obtained through the return line.

In one-pipe system the return line is closed by plug, the bleeding must be obtained through the nozzle or opening the pressure gauge port “P”, to accelerate the way out of the air.

GB TECHNICAL DATA

HYDRAULIC DATA

| | |
|-------------------|-----------------|
| Factory settings | 10 bar |
| Pressure range | 5 - 20 bar |
| Viscosity range | 2 - 12 cSt |
| Oil temperature | 0 - 60°C |
| Inlet pressure | 1,5 bar max |
| Return pressure | 1,5 bar max |
| Suction height | 0,45 bar max |
| Speed | 2800 - 3480 rpm |
| Starting torque | 0,10 Nm |
| Capacity | see graphs |
| Power consumption | see graphs |

GENERAL DATA

| | | | |
|---------------|---|-------------------|--|
| Mounting | Hub \varnothing 32 mm according to EN 225 | | |
| Connections | Nozzle outlet | G 1/8 | |
| | Pressure gauge port | G 1/8 | |
| | Vacuum gauge port | G 1/8 | |
| | Suction | G 1/4 | |
| | Return | G 1/4 | |
| Nozzle outlet | Left and Right | | |
| Filter | Open area | 9 cm ² | |
| | Mesh | 200 μ m | |
| Weight | 1,0 kg | | |

PRESSURE - CAPACITY DIAGRAM

Viscosity 5cSt

Speed 2800 rpm

Diagram considers a wear margin.

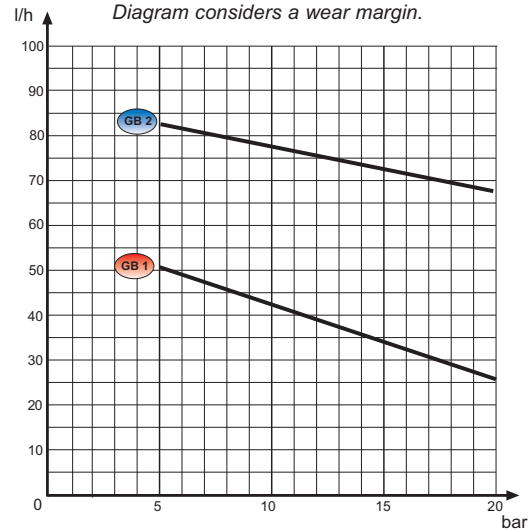

POWER CONSUMPTION - PRESSURE DIAGRAM

Viscosity 5cSt

Speed 2800 rpm

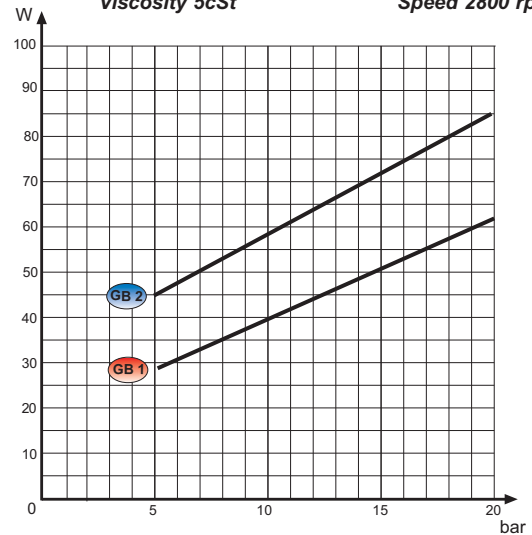

DIMENSIONS OF THE PUMP

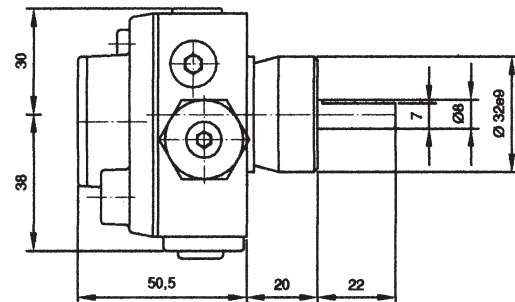
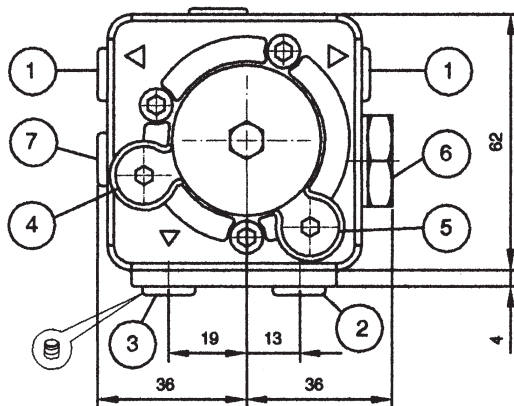

Legend:

- | | |
|-------------------------------|-----------------------------------|
| 1 - Nozzle outlet G 1/8 | 5 - Vacuum gauge port G 1/8 |
| 2 - Suction G 1/4 | 6 - Pressure adjustment screw |
| 3 - Return G 1/4 | 7 - Auxiliary delivery port G 1/8 |
| 4 - Pressure gauge port G 1/8 | |

KB TECHNICAL DATA

HYDRAULIC DATA

| | |
|-------------------|-----------------|
| Factory settings | 7 bar |
| Pressure range | 4 - 14 bar |
| Viscosity range | 1 - 12 cSt |
| Oil temperature | 0 - 30°C |
| Inlet pressure | 1,5 bar max |
| Return pressure | 1,5 bar max |
| Suction height | 0,45 bar max |
| Speed | 2800 - 3480 rpm |
| Starting torque | 0,10 Nm |
| Capacity | see graphs |
| Power consumption | see graphs |

GENERAL DATA

| | | |
|---------------|---|-------------------|
| Mounting | Hub \varnothing 32 mm according to EN 225 | |
| Connections | Nozzle outlet | G 1/8 |
| | Pressure gauge port | G 1/8 |
| | Vacuum gauge port | G 1/8 |
| | Suction | G 1/4 |
| Nozzle outlet | Return | G 1/4 |
| | Left and Right | |
| Filter | Open area | 9 cm ² |
| | Mesh | 200 μ m |
| Weight | | 1,0 kg |

PRESSURE - CAPACITY DIAGRAM

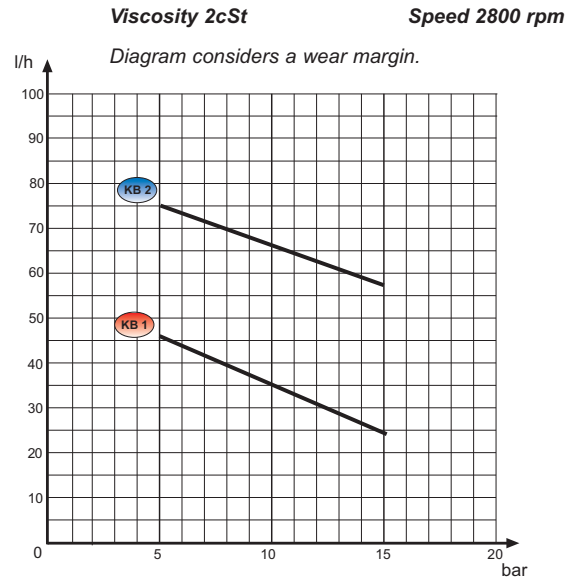

POWER CONSUMPTION - PRESSURE DIAGRAM

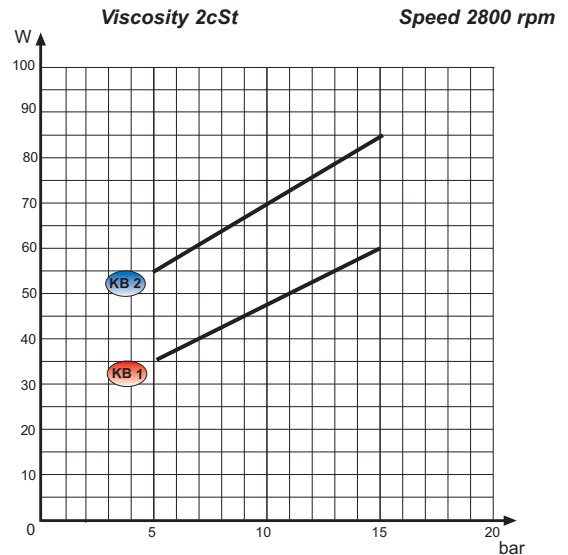

IDENTIFICATION OF THE PUMP

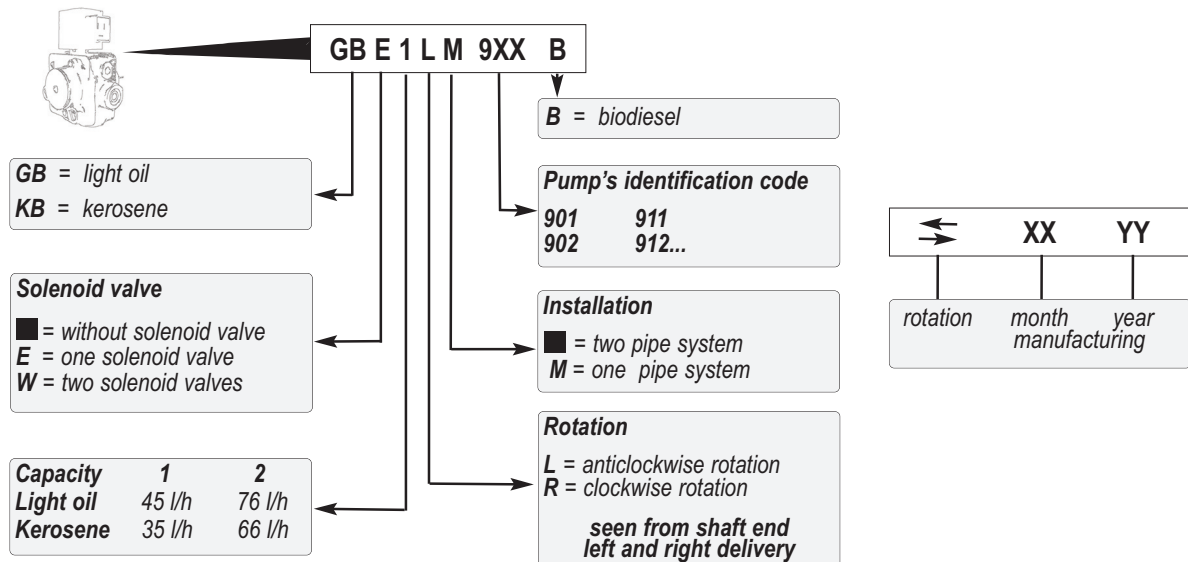

COMPONENTS OF THE PUMP

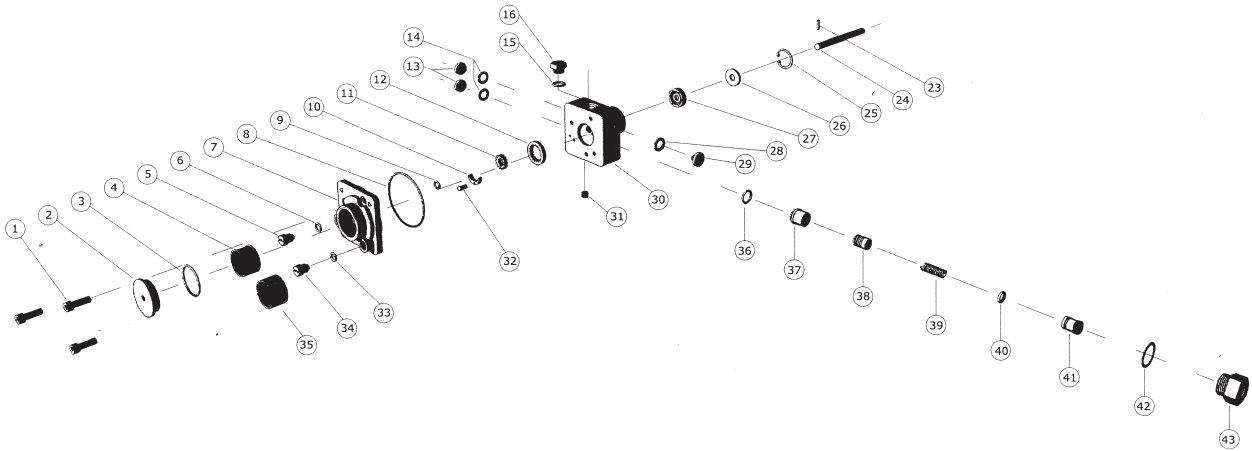

INSTALLATION OF THE PUMP

- The pump can be installed in all indicated positions.
- Make sure that the characteristics of the pump are compatible with those of the motor or of the boiler.
- Control the rotation of pump-motor.



The coupling pump-motor must be realized using 3 head screws without; otherwise you can have significant reductions of pump life.

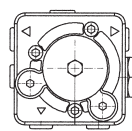

a

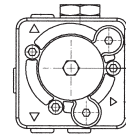

b

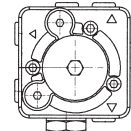

c

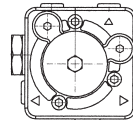

d

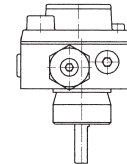

e

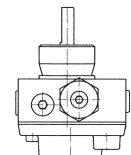

f

REGULATION OF THE PUMP PRESSURE

- Apply the manometer on the pressure gauge port (P).
- Rotate with the allen key of 4 mm changing the pressure which has to be:
 - Pressure max: 20 bar (light oil) - 14 bar (kerosene)
 - Pressure min: 5 bar (light oil) - 4 bar (kerosene)

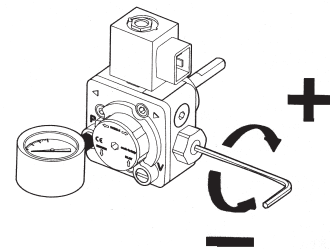

CLEANING OF THE FILTER

- Remove the cover as indicated in the position 1.
- Extract the filter and clean it with the clean oil fuel (position 2).

ATTENTION: This operations have to be made periodically by the technical personnel.

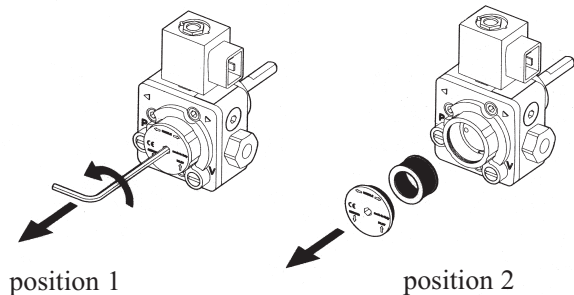

The repairs which require the substitution of pieces, must be realized by the manufacturer.